

TAKEO'S TALE OF WORKFLOW IMPROVEMENT

Questetra, Inc.

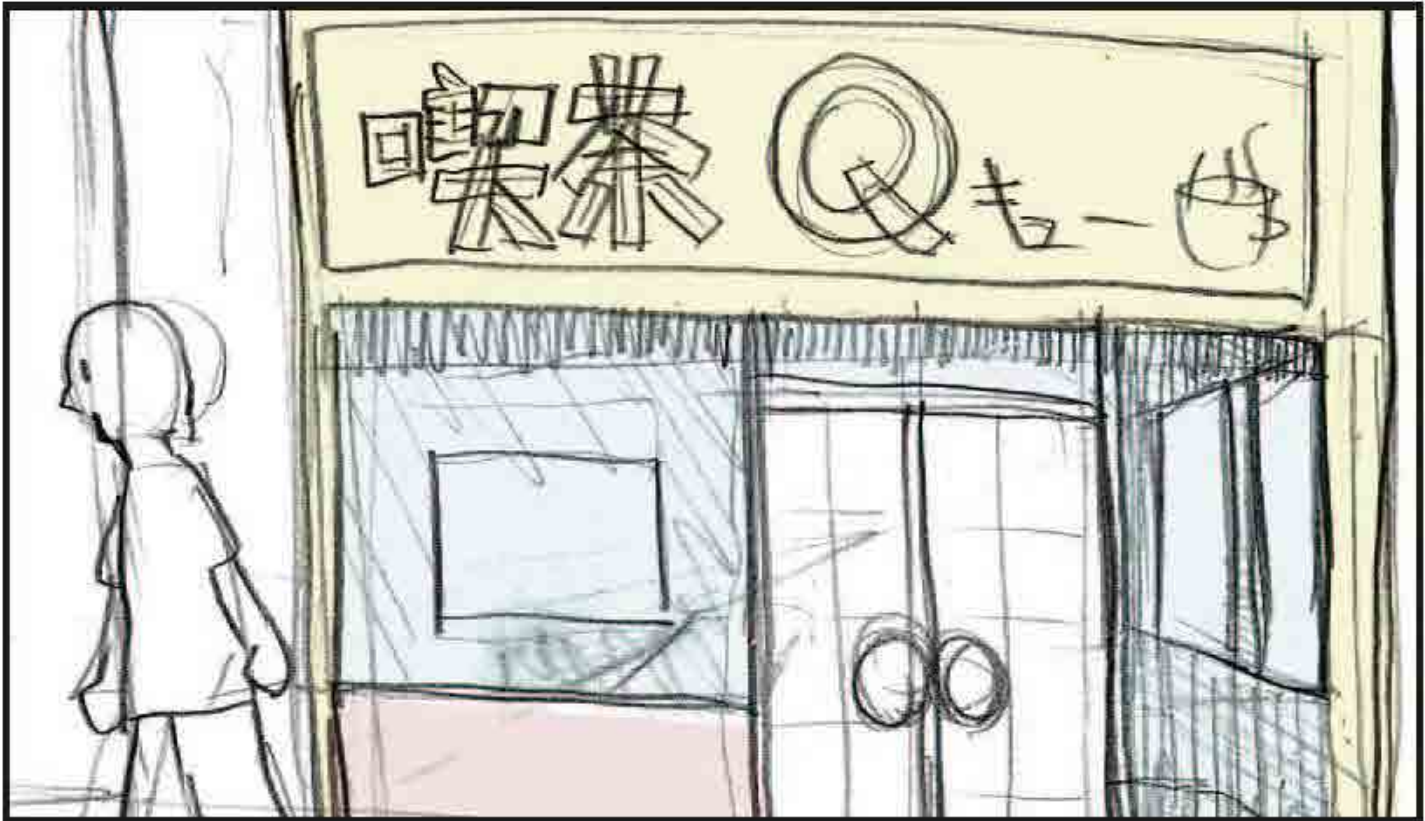

One afternoon...

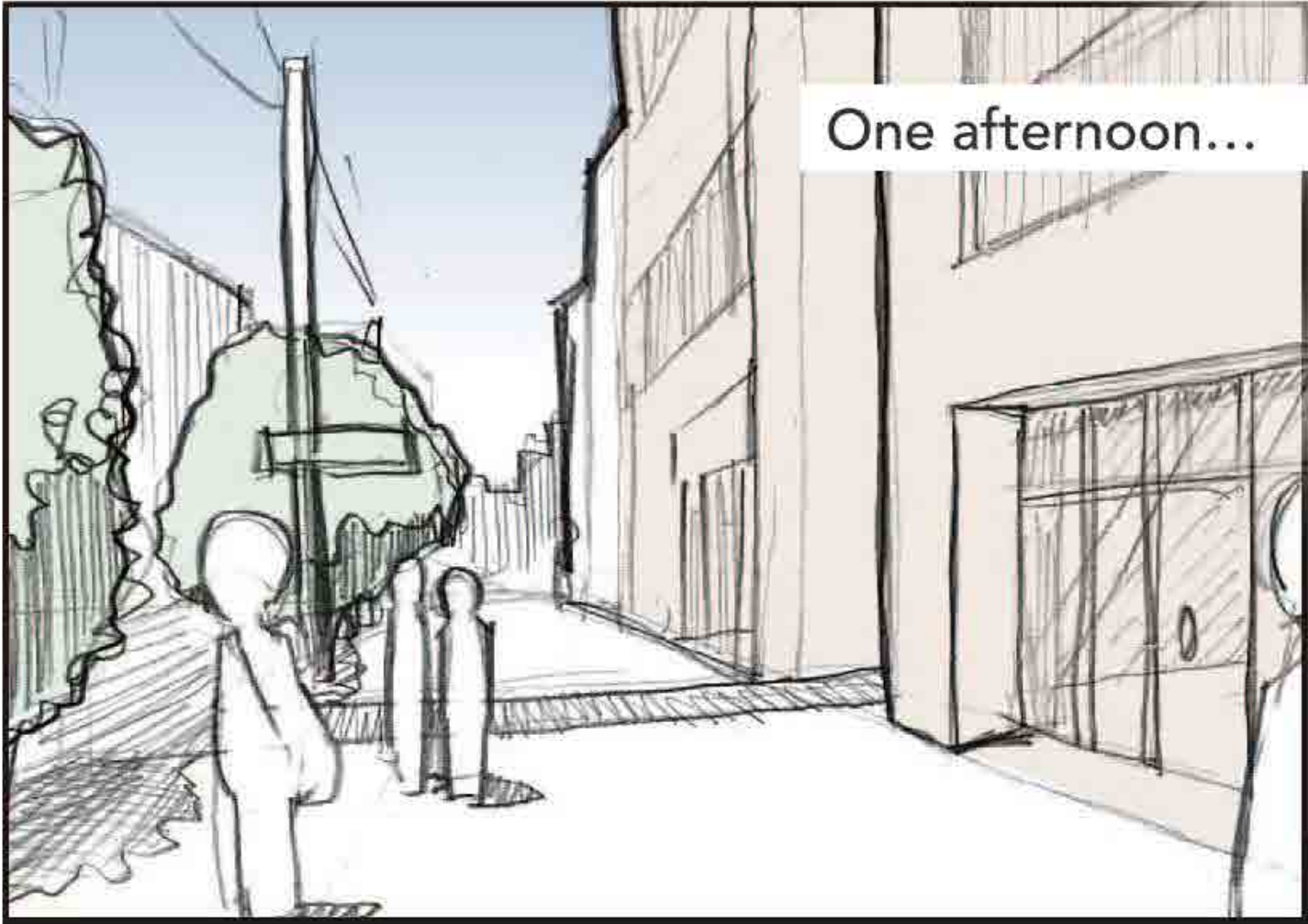

**This young guy,
TAKEO is the hero of this story.**

How are you doing?
Seems good, you and the company
you're working for.



This guy is ICHIRO.
He was a class mate of TAKEO,
and now he works for "HACHIKU Commerce",
one of the best in the business.

Well, I don't Know,
but...



They leave me some big deals recently. I
wonder how much I am talented. By the way,
you've gotten a job in "TAKETORI
Firm", haven't you? I heard it's a
micro-enterprise that a family runs. Isn't it
too small for a X college grad?



You'd better follow my
example, enjoy your life
elegantly.
Or is that difficult for you?

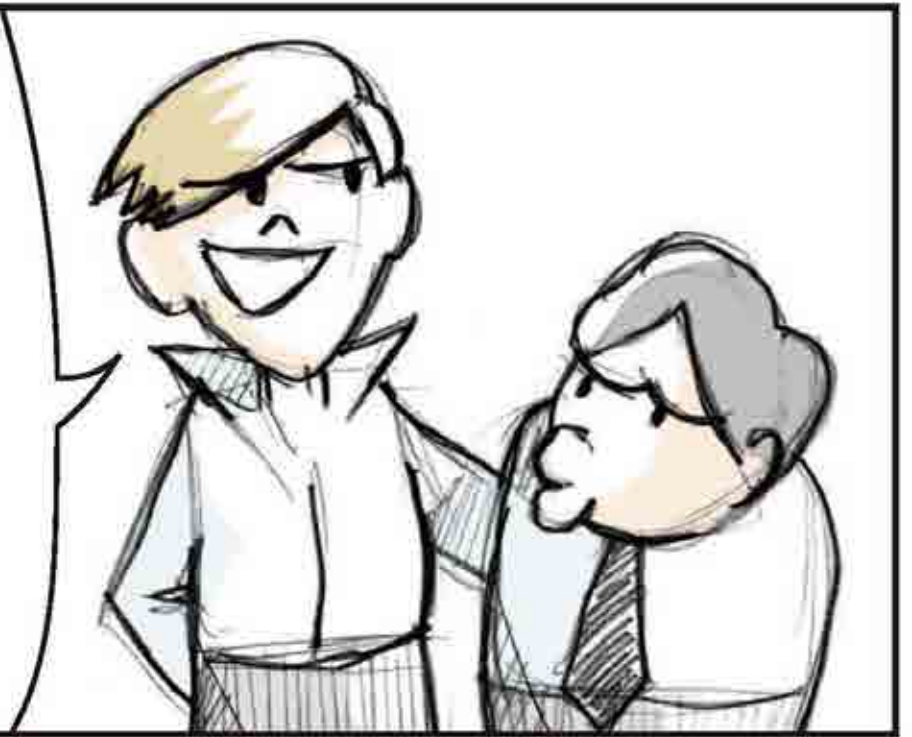

See you sometime.
Get yourself in gear!

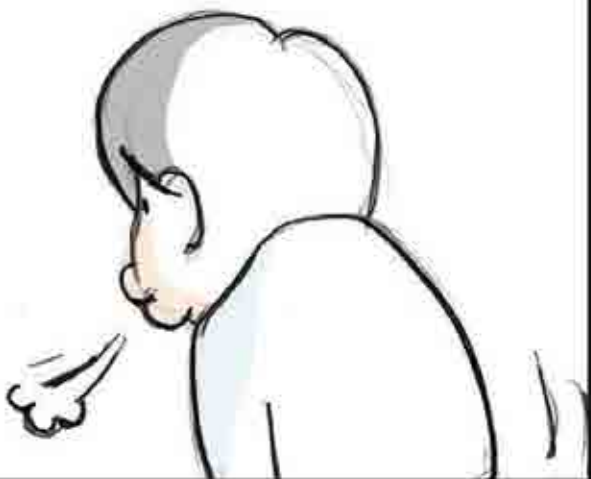



This is TAKETORI Firm where TAKEO works for. They deal bamboo materials and

They used to be famous with their "TAKETORI's Comb", purveyors to the Imperial Household Agency. But now they are a dispirited micro-enterprise.



TAKEO was born and raised in Kyoto. And he is interested in handicraft art, so he chose the company to work.

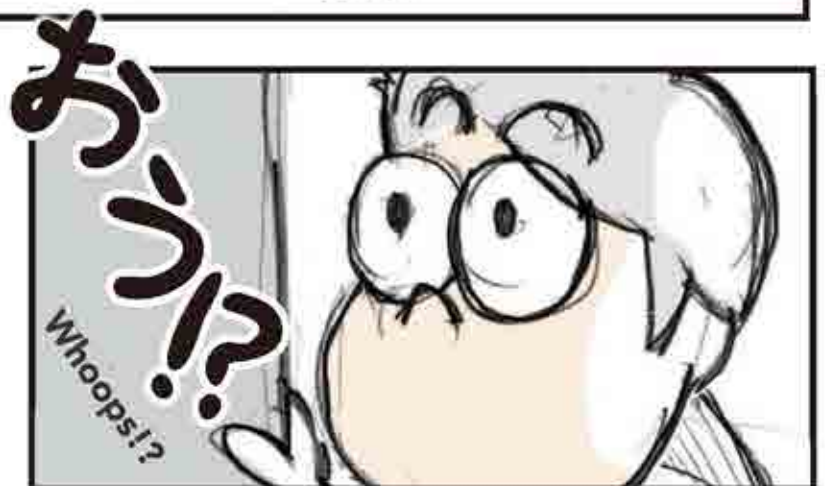



What a hell is it?

Office is filled up with bamboos!

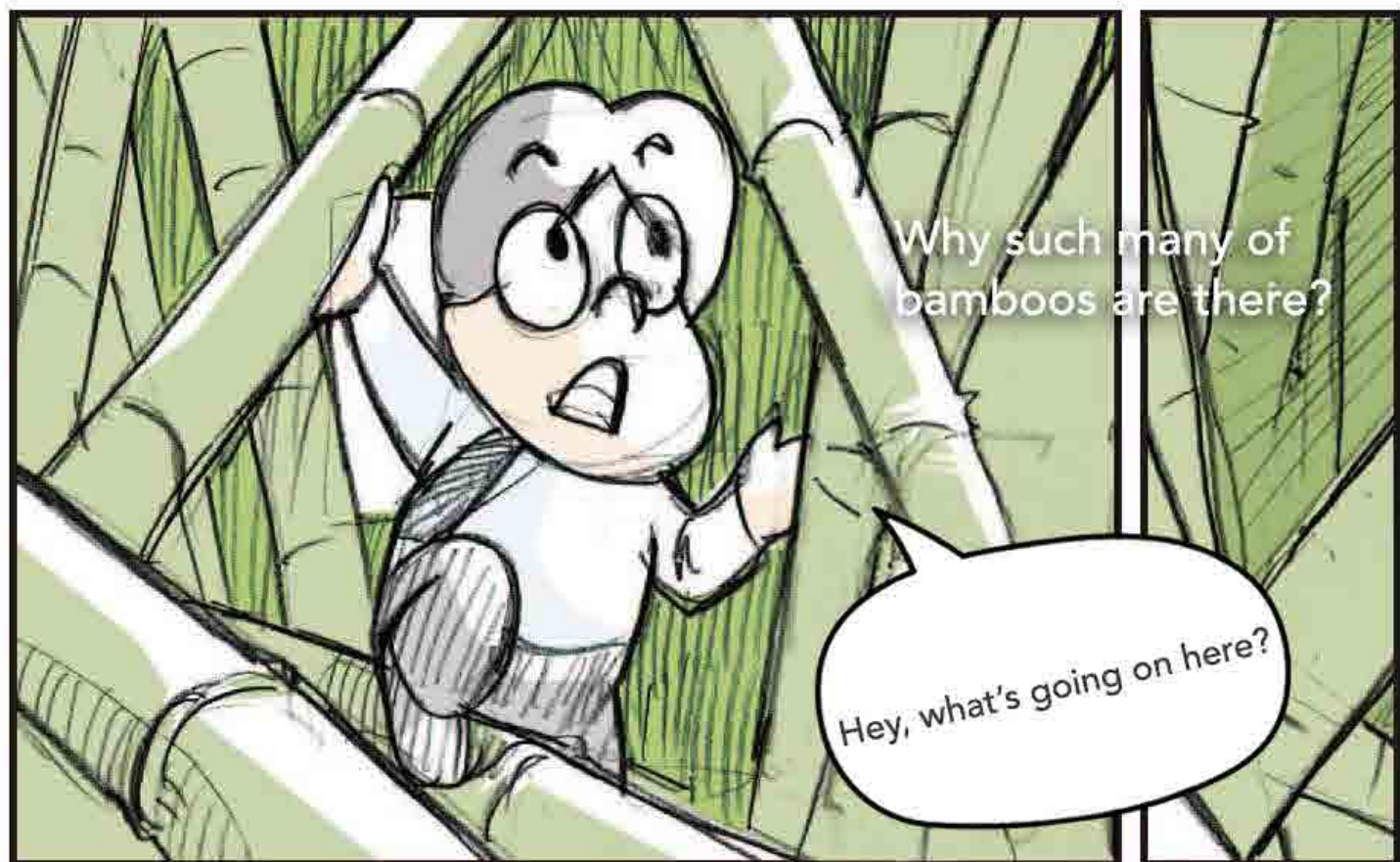

Why such many of bamboos are there?

Hey, what's going on here?



Oh!
There you're back.



This is **Uncle Sales**, sales person of TAKETORI Firm. Also supervisor of TAKEO.



Well well, Aunt clerk made a multiple order...Mistake!



What are you talking about?!



Aunt Clerk



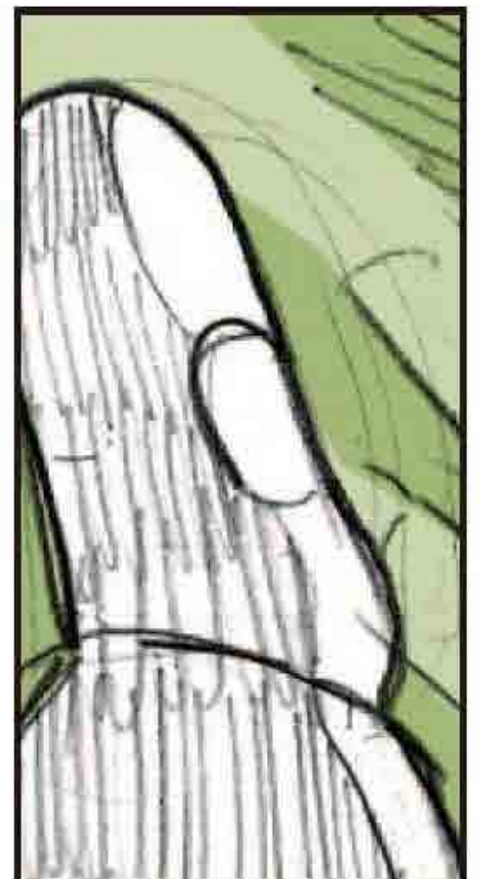

Well, I 'm too busy...

Can you handle that?



Nobody has a sense of crisis even on fault order...
Nobody understands what's going on...
Sales is little bit... No hope ...for such a company...



SNAP







What a surprise!
An old man appeared from the bamboo
that TAKEO smashed for his madness.



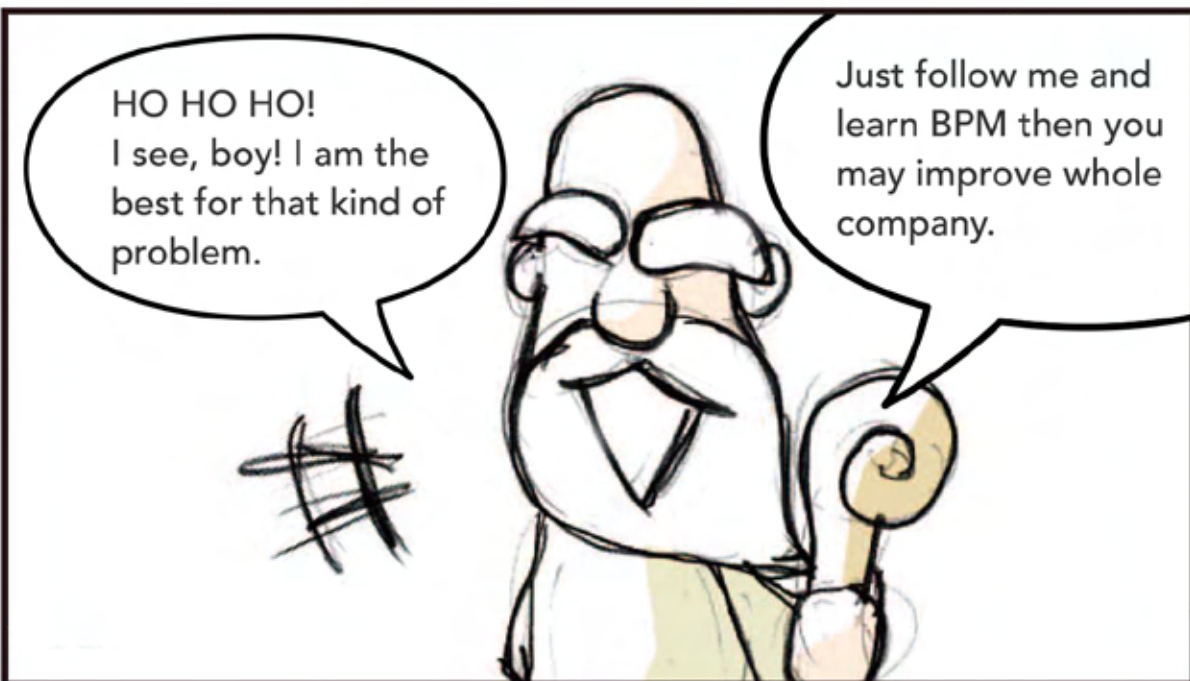
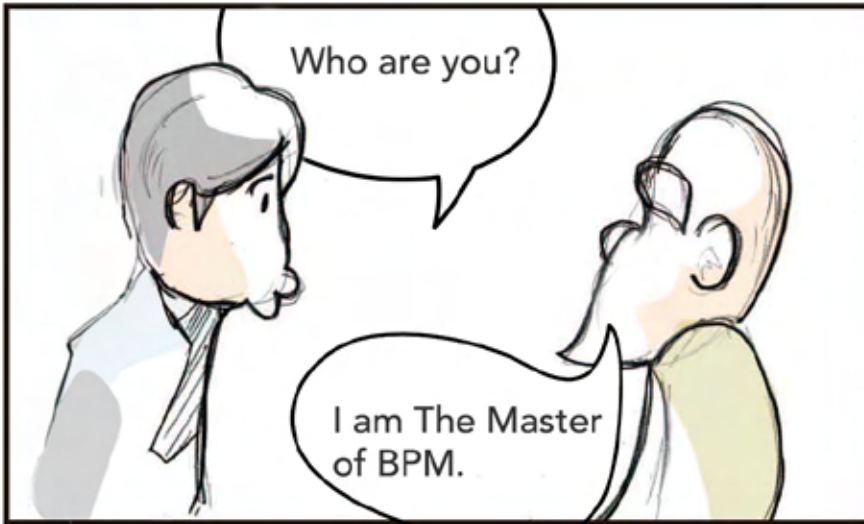

**B
P
M
?**



What's BPM?

YAHAGI, Questetra, Inc.

It stands for **B**usiness **P**rocess **M**anagement.

Arrange & Analyze business flow



Find out problems



The best procedure



Its goal is the improvement of **QCD**.

Quality

Bad → Good

Cost

Expensive → Cheap

Delivery

Slow → Quick

Happiness for all !



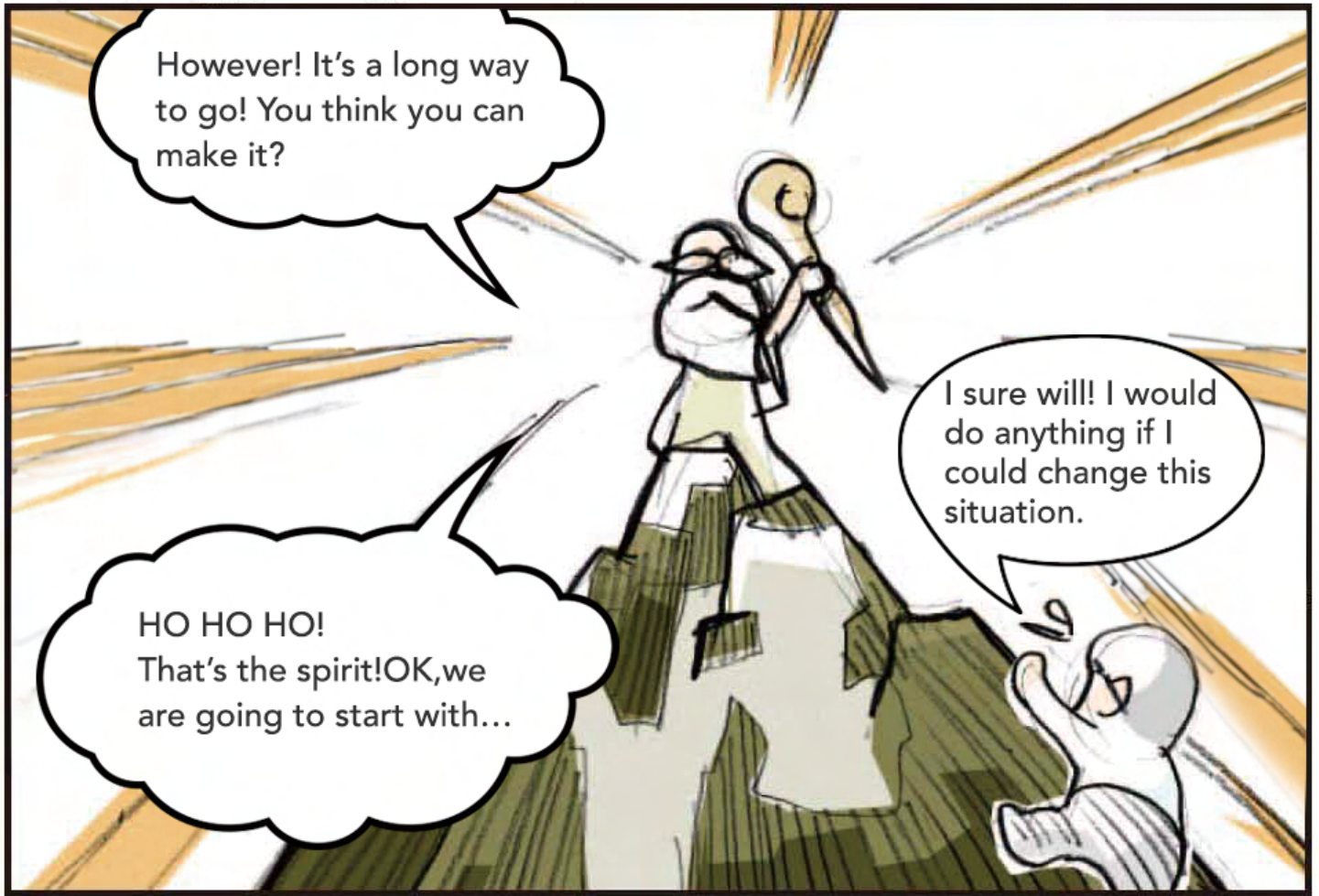

LESSON 1

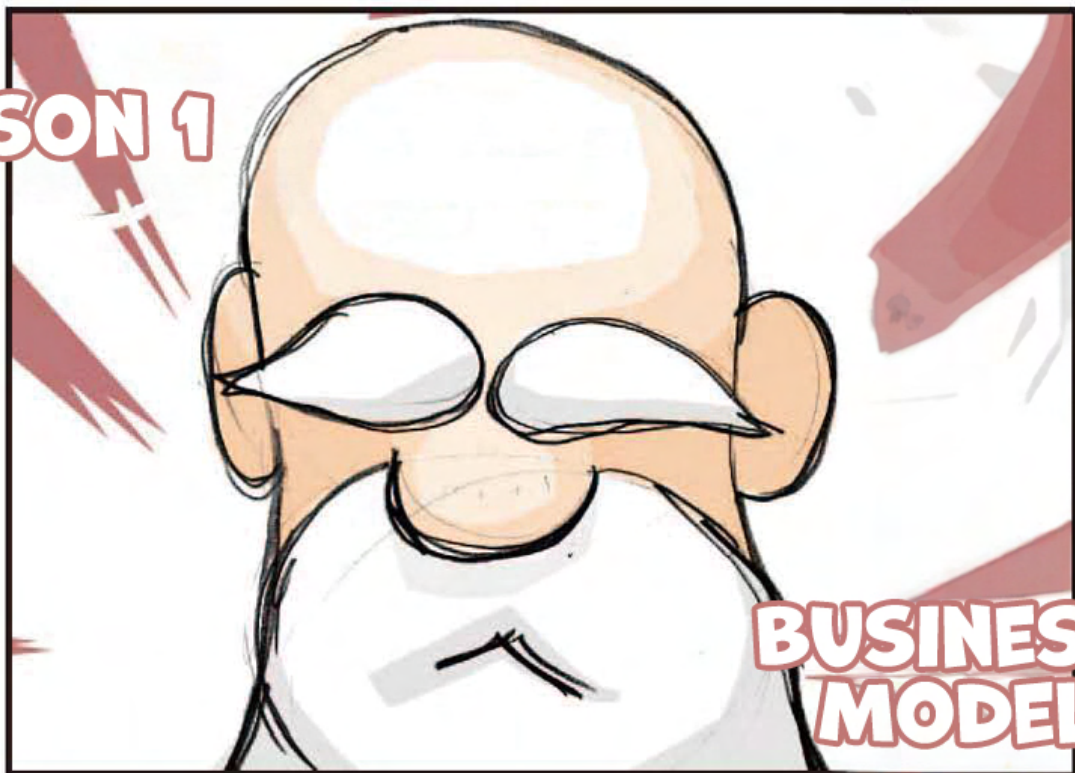

Business Modeling??



What's Business Modeling?

YAHAGI, Questetra, Inc.

BPMN means Business Process Model and Notation.

Show the beginning of a business issue

Activities

Person or a team

Start Event

Tasks

Swim Lane

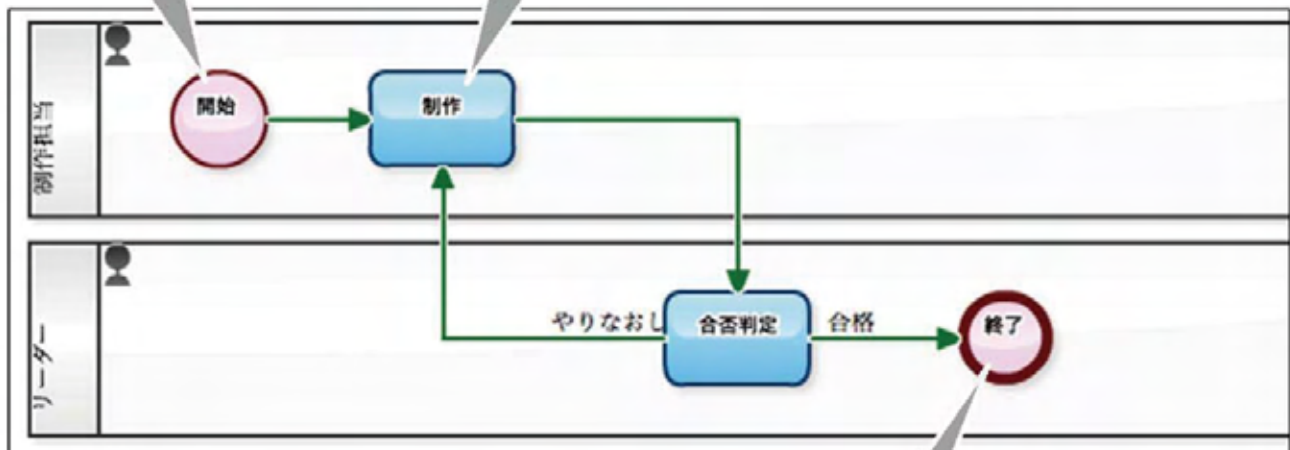

There is a various symbols to represent complex business flow.

End Event

End of a business Issue



YAHAGI's Commentary on BPM



What Will Happen by Modeling Business?

YAHAGI, Questetra, Inc.

Something Comes Into View Just by Arrange "As-Is"

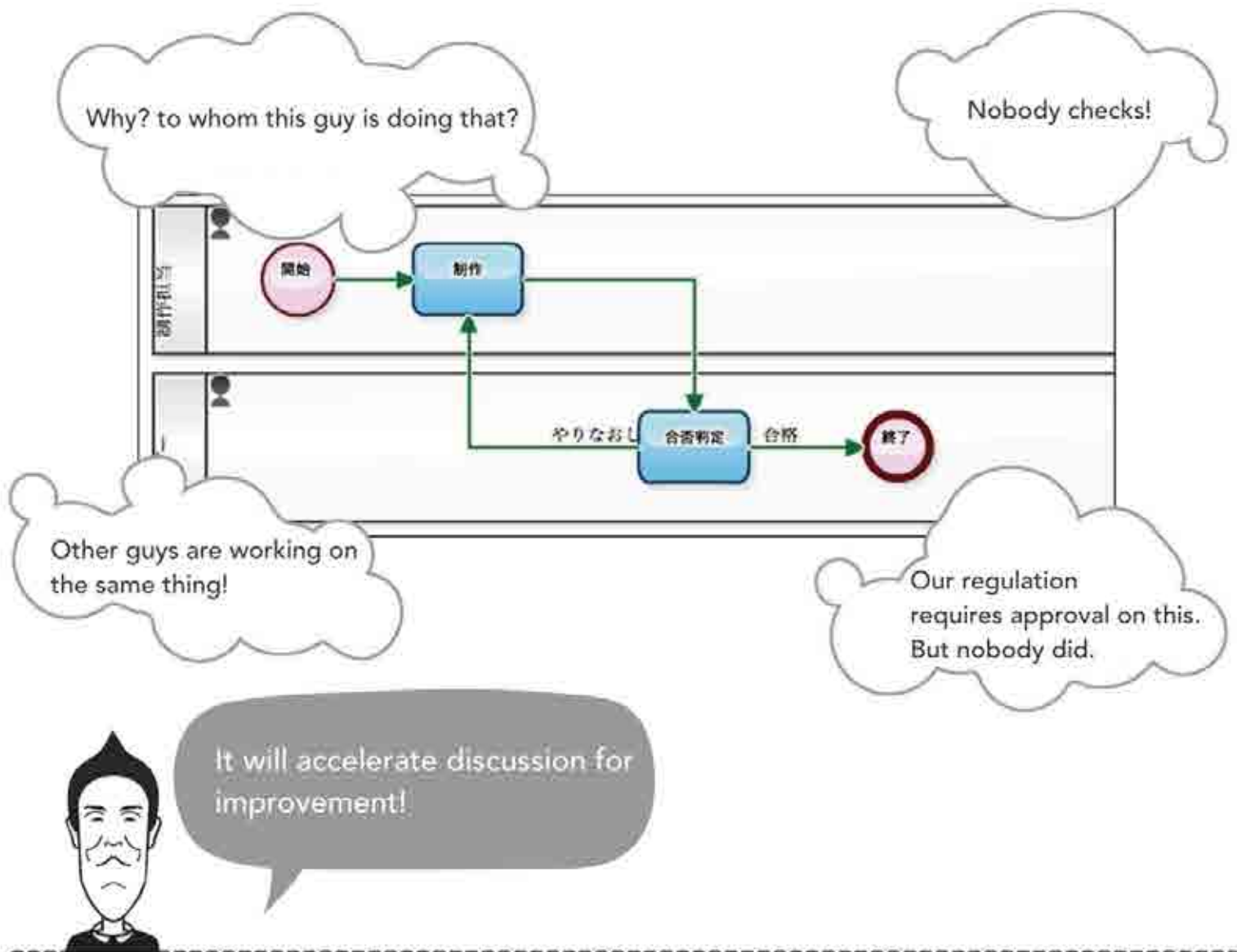

Huff...I have done at last!

Ho Ho Ho, Let's see...

Business Flow Chart that TAKEO drew

Made with hearing from co-workers

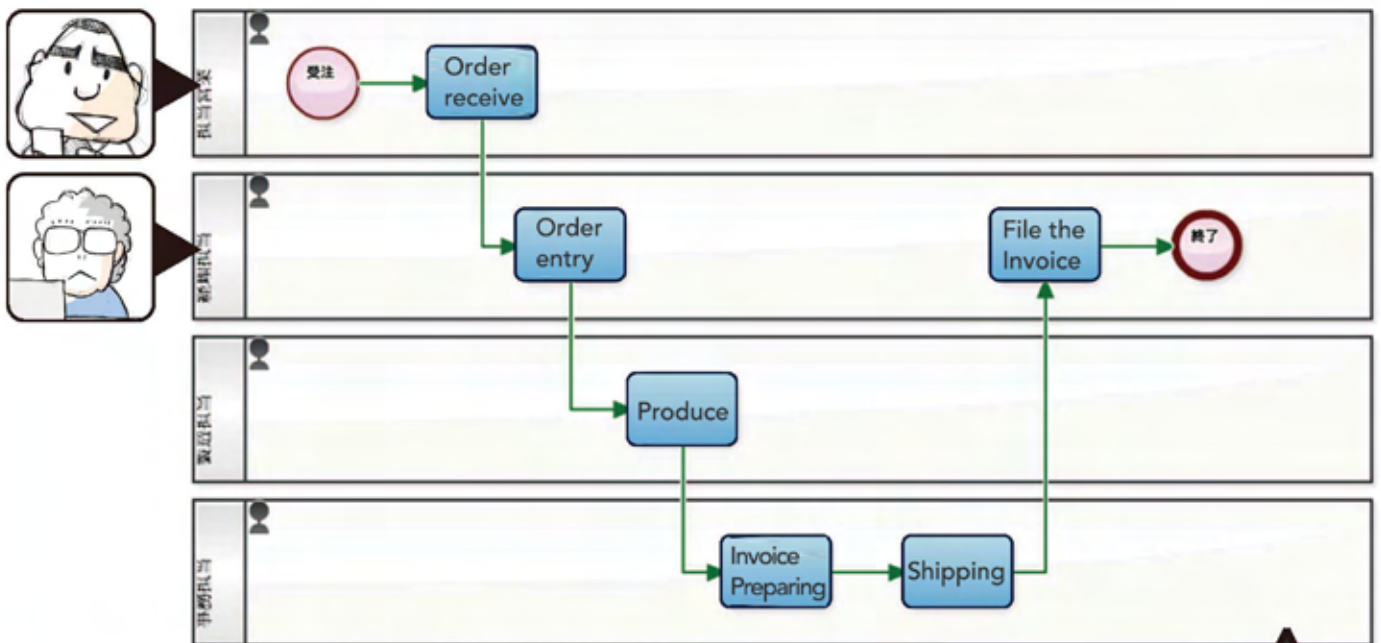

- Not clarified business flow (Only verbally told so far)
- Haven't billed properly (Invoices are not kept)
- No prospect can be made (Clerk haven't told about manufacture and shipping)

etc.

Making a chart with BPMN, unclear business flow can be understand simple and clear.





Hey!
President!

We have lots of problem in our firm! Flow of business is unclear, too much depending on experience and intuition, lots of unreasonableness and uselessness!

Let's improve them along this business flow chart!

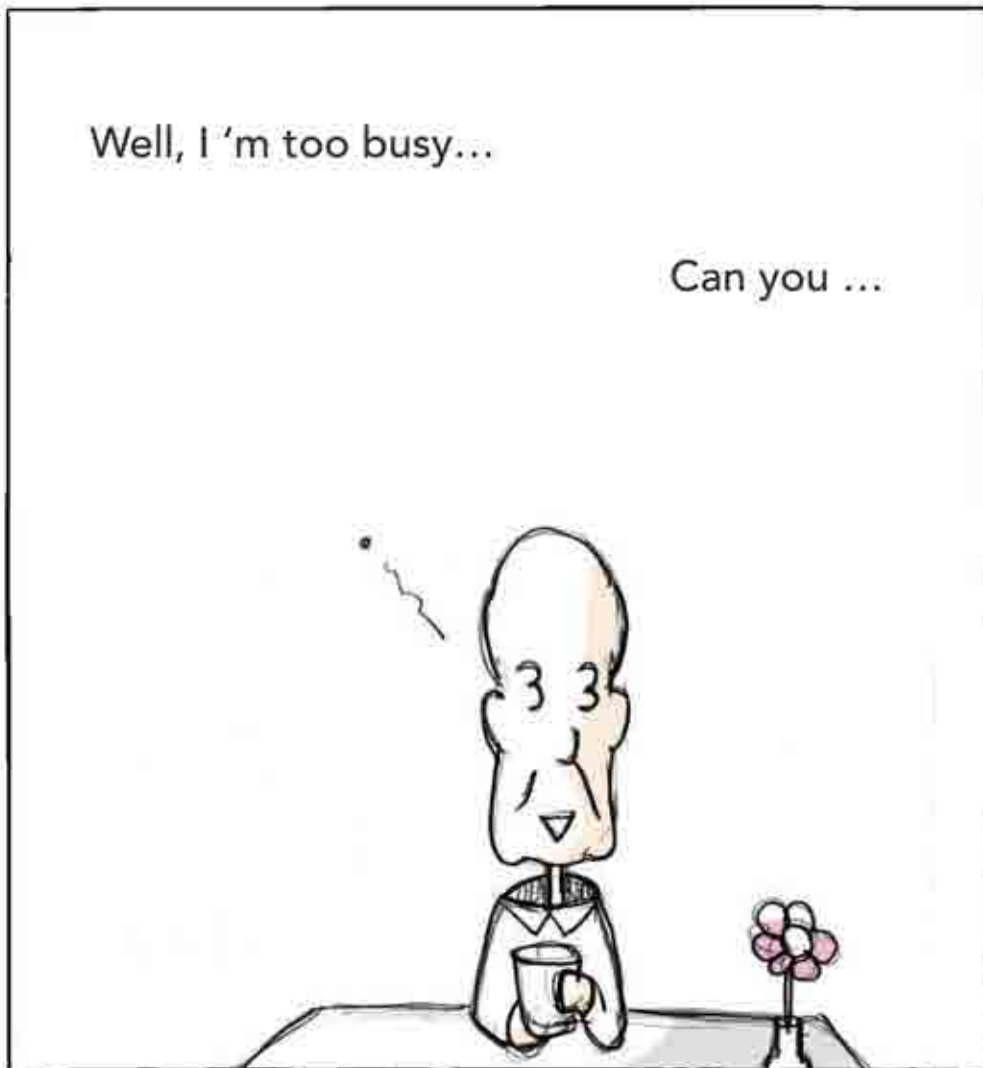

Well, I 'm too busy...

Can you ...

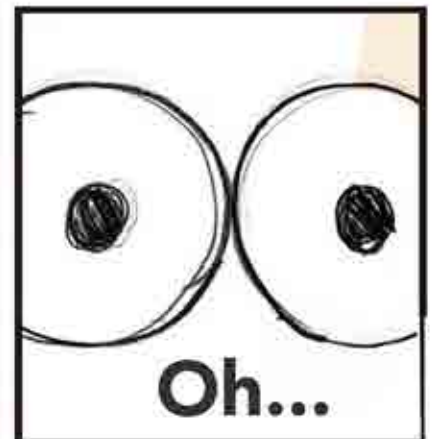
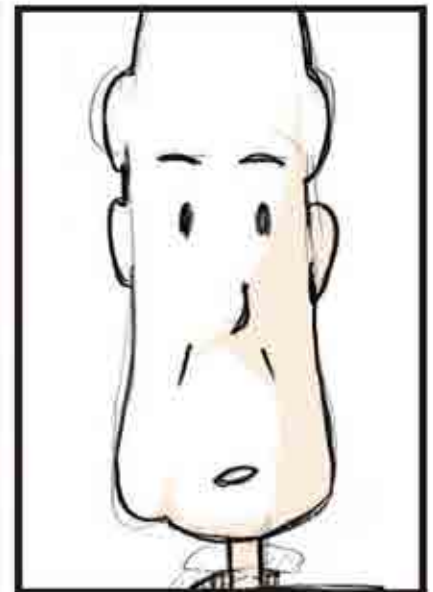

Oh...



Well done, TAKEO!
I adopt this as a business regulation! Hey!
Everybody, form now on,
work along this business chart nice'n Clear!



ADOPT

Booo...
Tiresome...



Don't worry! Leave it to Questetra!!

YAHAGI's Commentary on BPM



Business Goes Just Like as The Workflow You Designed

YAHAGI, Questetra, Inc.

Once Workflow chart is designed, entry forms (screen) for proceeding it are automatically generated. Questetra BPM Suite is Automatically Generated

The workflow created by Takeo

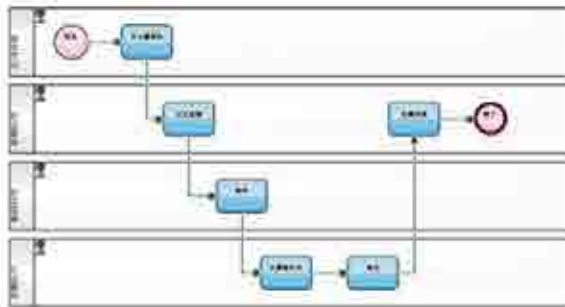

automatic generation



Form for Uncle Sales



Form for Aunt Clerk



Task is automatically passed to the next person in charge after inputting data in entry form. Although applying new regulation is very hard, this make everyone feel fine and easy.

A Month later

Workers got used to BPM day by day, by TAKEO's enthusiastic teaching BPM.



All I gotta do is to input, then the business goes on. ...and no more communication error.

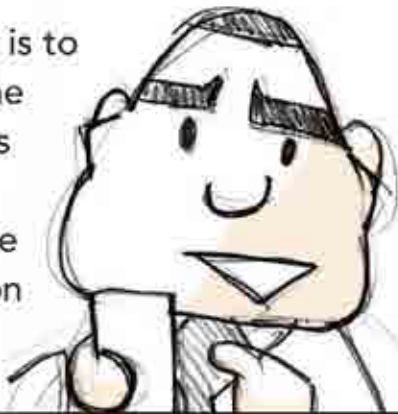

It's good and easy to understand the flow of business. ...and progress.

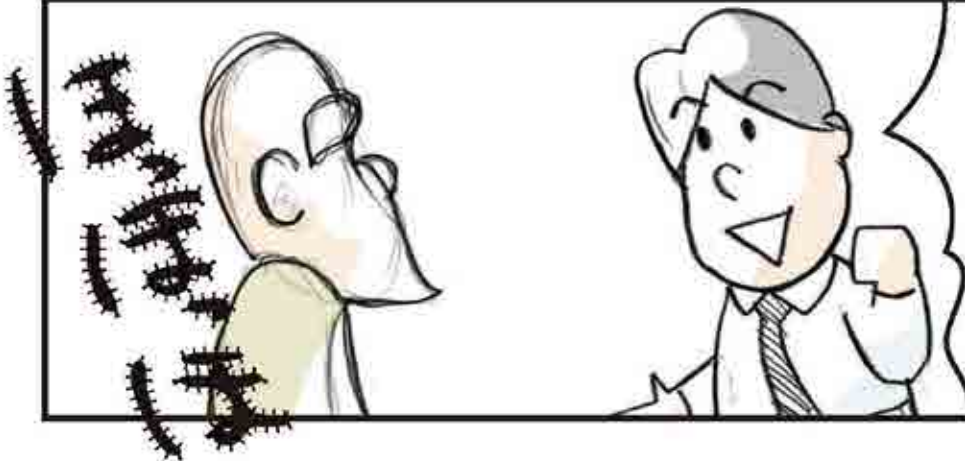

Master! Thank you very very much! Finally, I could manage to make works going nice 'n smooth!



What's Optimization?

YAHAGI, Questetra, Inc.

Practical Business Data has accumulated.
To find out problem from those data and to improve
business flow is Optimization.

For example,

Finding out bottle neck in the state of business.

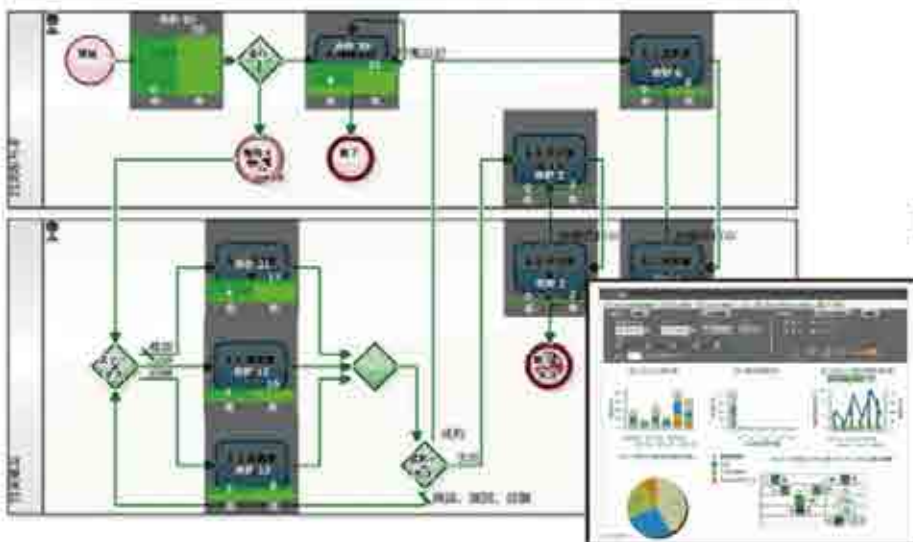

Stranded Hours
Number of transactions
Average
Processing Time



Only a glance all over the
business by Questetra BPM
Suite!

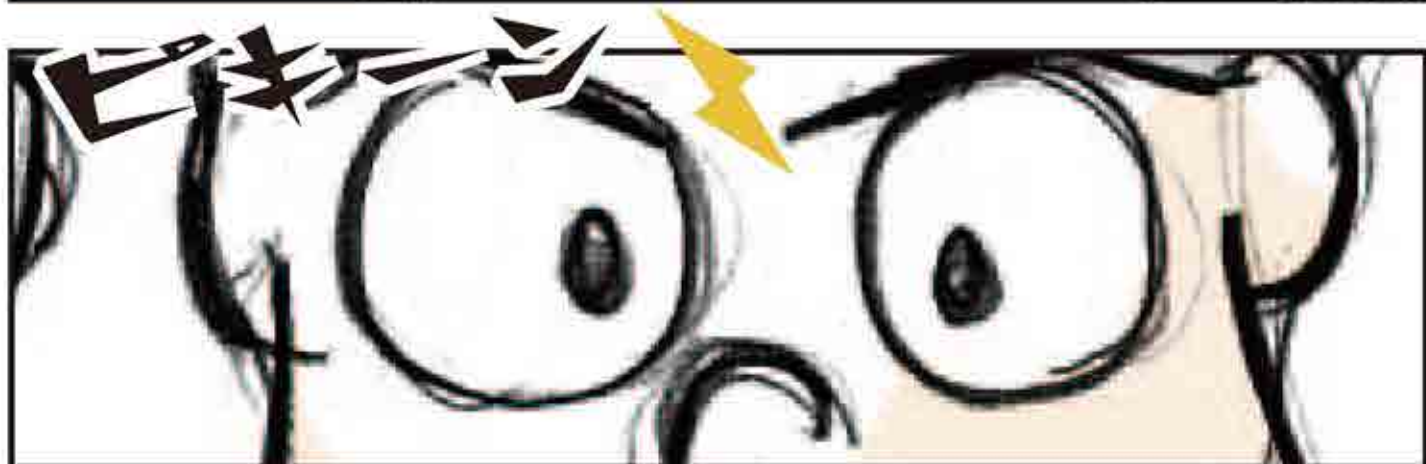

※No Super-Power needed for finding problem





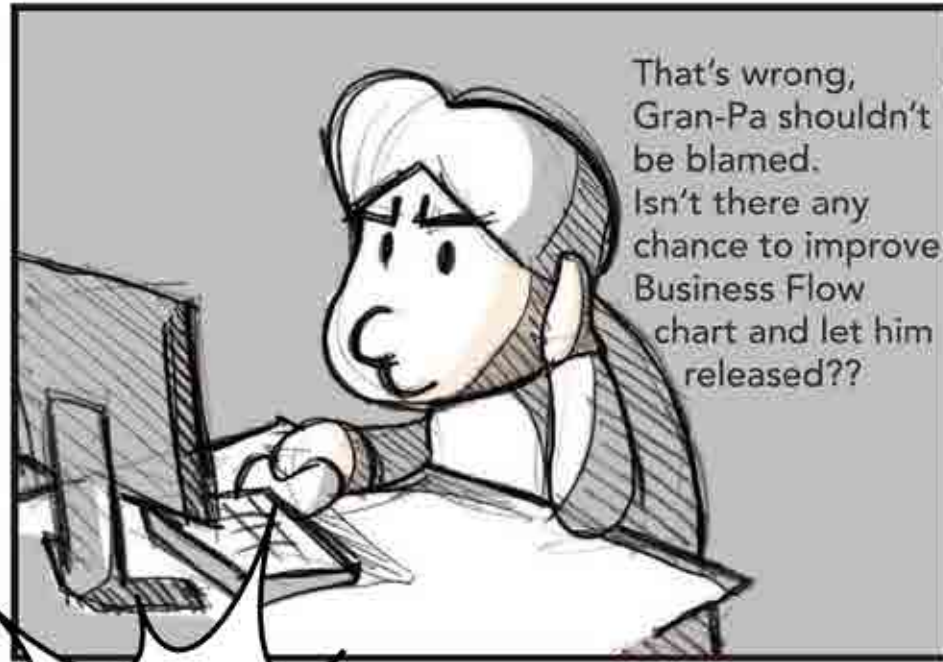

That's wrong,
Gran-Pa shouldn't
be blamed.
Isn't there any
chance to improve
Business Flow
chart and let him
released??

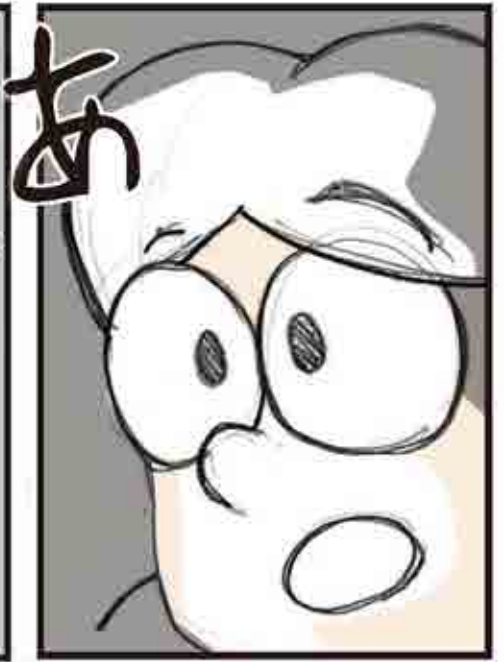

I see it!

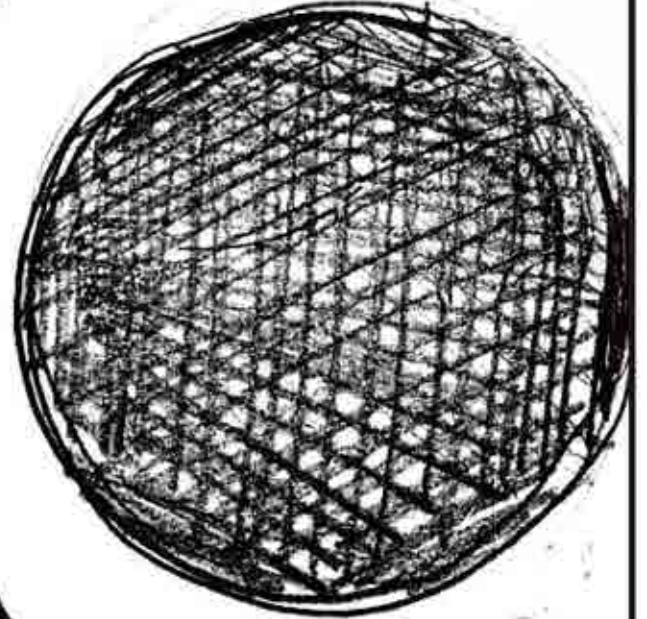
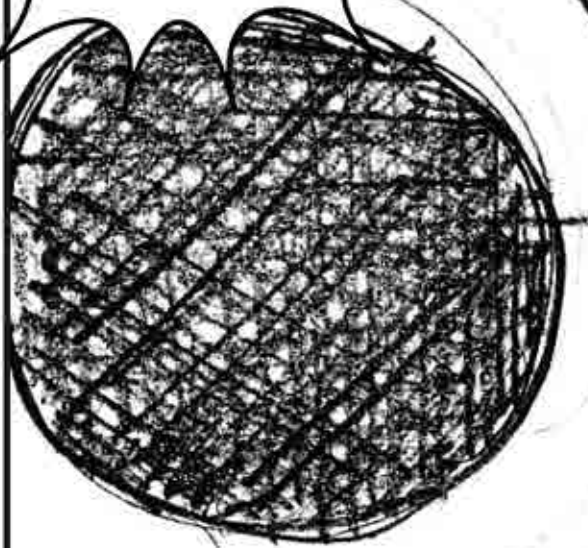

I seeeeeeeee it!

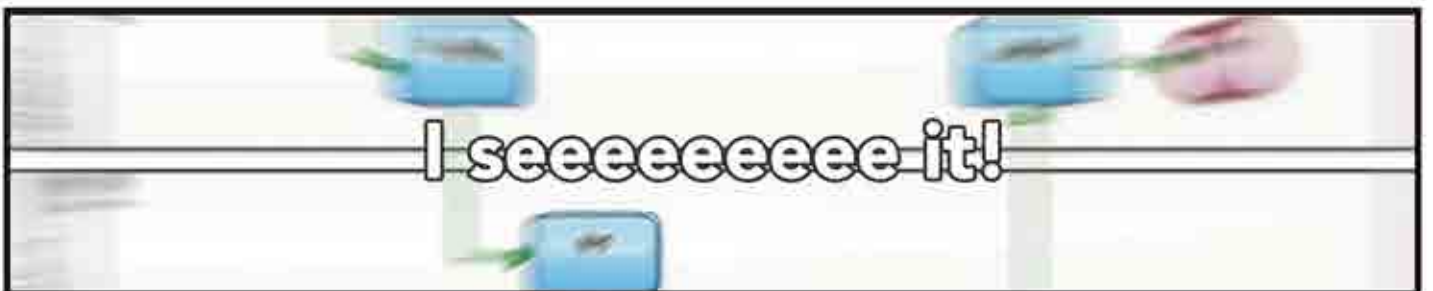



YAHAGI, Questetra, Inc.

What TAKEO Has Seen?

Let's take a look at the TAKEO's Workflow diagram, again.

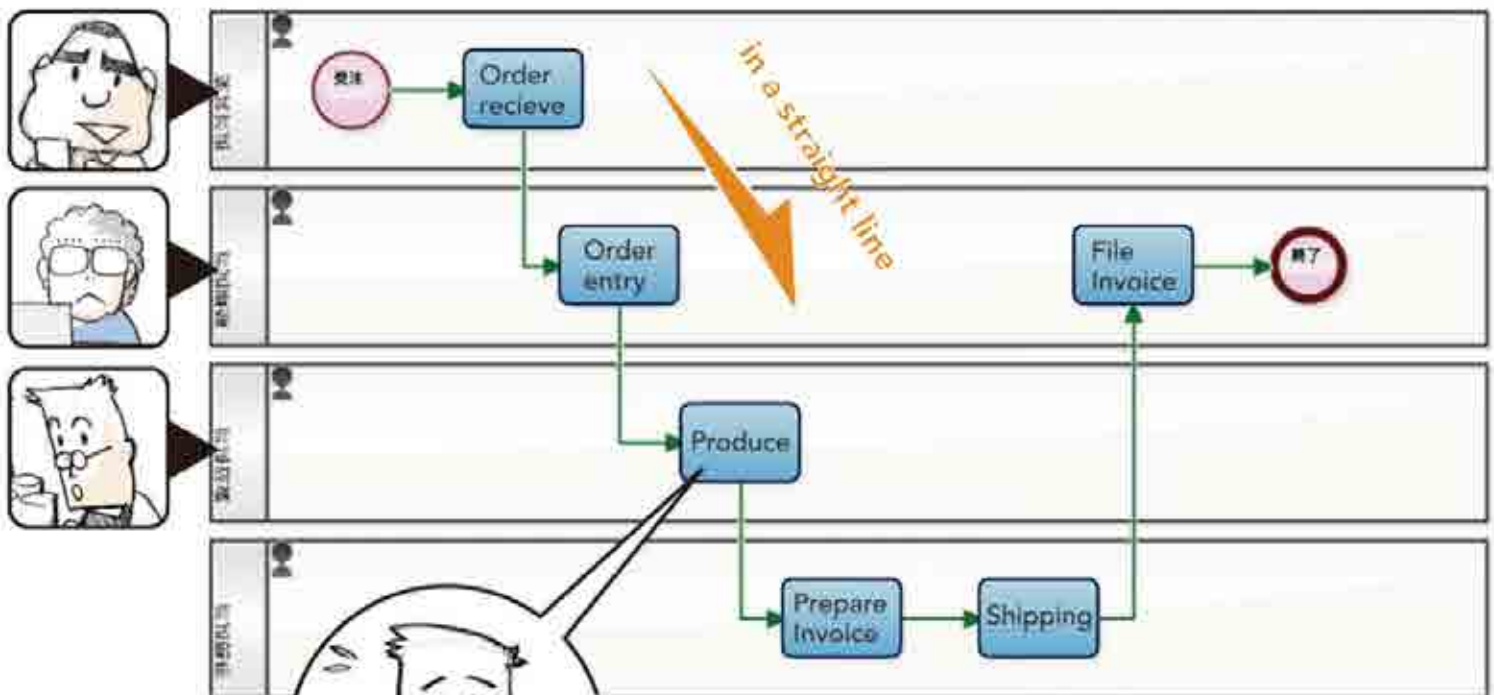

- There is a big difference between the busy season and the low season
- Too long overtime work
- Stagnation occurs often

How can we improve this workflow to average the grandpa's work that fluctuates?



Order entry

He couldn't start production until "Order entry" had registered.



Ex.



Concurrent Processing helps him start earlier.

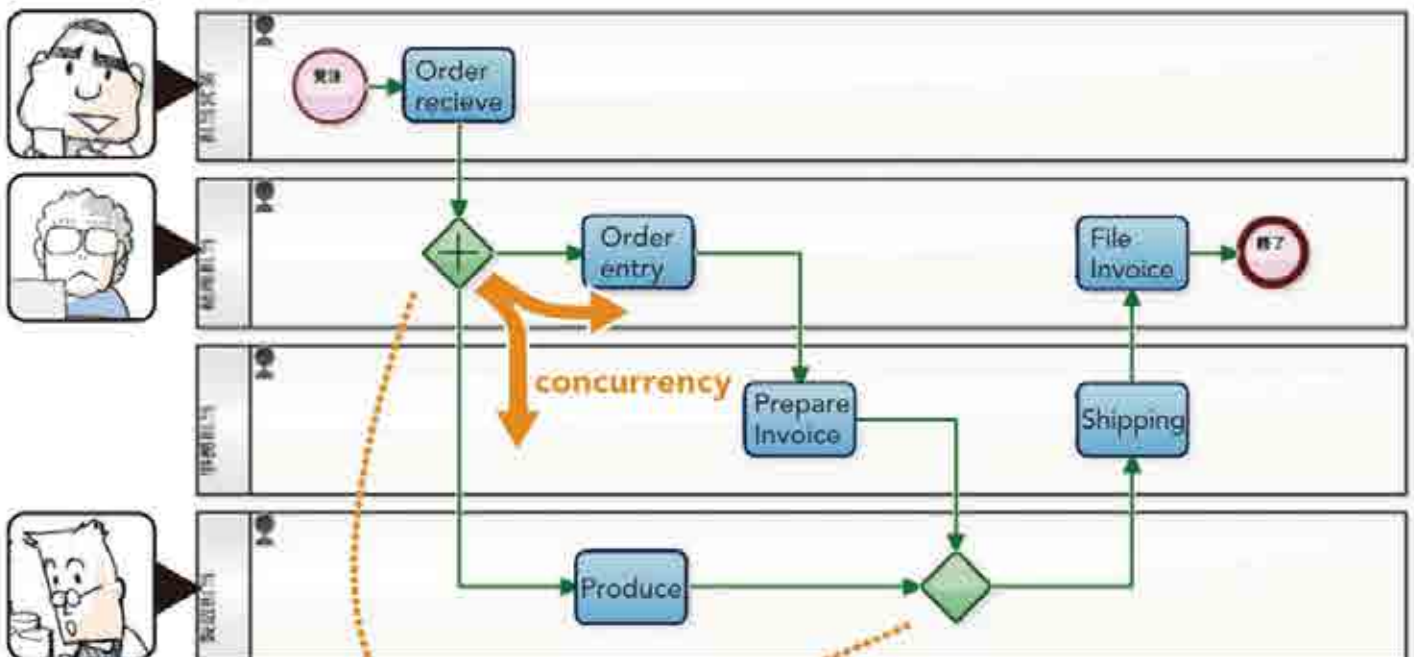

As he has become able to start producing upon an order coming in, his time to spend producing increased, so now the fluctuation is absorbed.



It's also good "Create Invoices" can start before "Production" has complete. Concurrent Processing is one of the effective improvement.

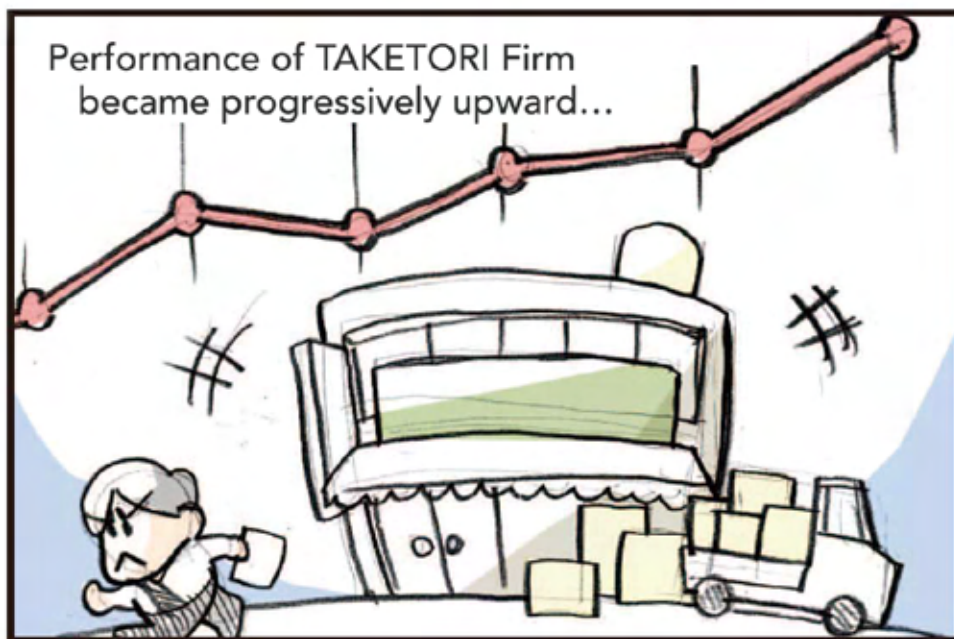
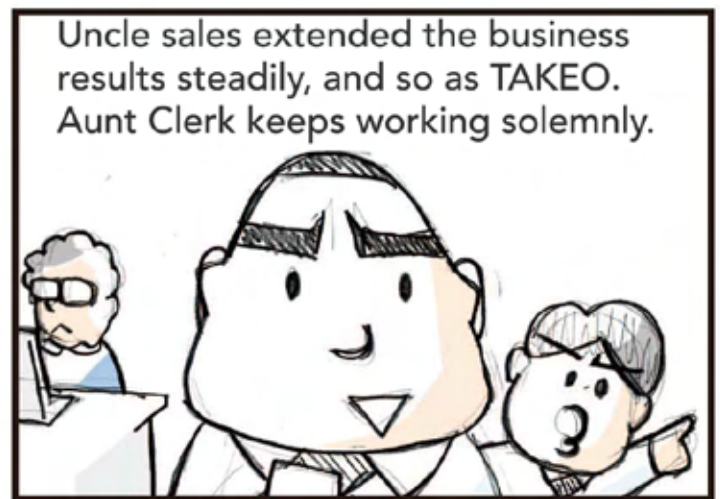

Whole team has got together for business improvement with BPM, and almost succeeded...



Business goes effectively, and sales are now good. Now I feel at ease.



You cretiiiiiiiiiiiiiiiiiiiii again!



Fool, you think you are through?

YOU'VE GOT TO LEARN LESSON 3

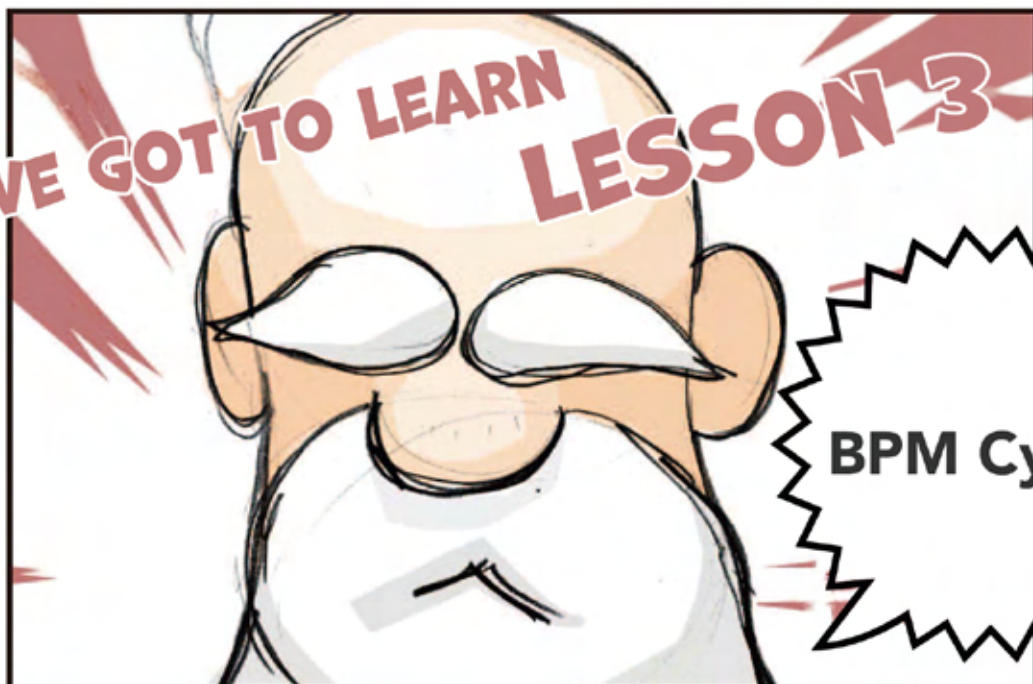

BPM Cycle!

BPM Cycle?



YAHAGI, Questetra, Inc.

What's BPM Cycle?

A Cycle of PDCA that Focused on Work Flow

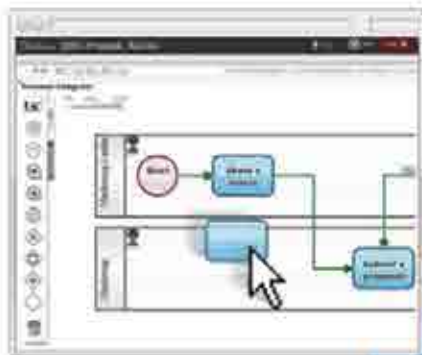

Planning Workflow
(Modeling)



Doing task (Execution)

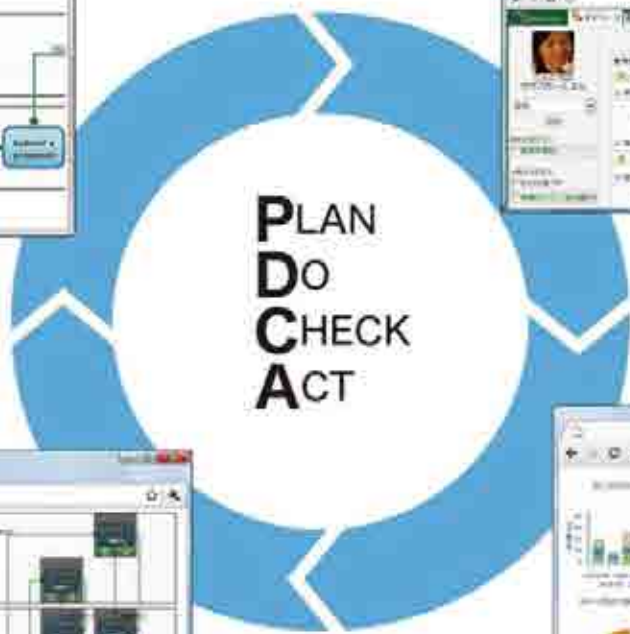

Monitoring operations



Analysis on Record



Nobody can design perfect Model from the beginning.
And as the organization or legal systems change, Workflow must be improved
and optimized responding to those changes.

TAKEO challenged continuously for further improvement, and tried to apply BPM to every business operation.



Uncle Sales became an Ace salesman.



Aunt Clerk kept on working solemnly.



Gran-Pa's skill as a craftsman has further brushed up, he developed a new product during the spare time made by optimization of business operation.



THE NEW PRODUCT



The new product "Delu-Xi" became a news in town for its record-breaking size and quality.

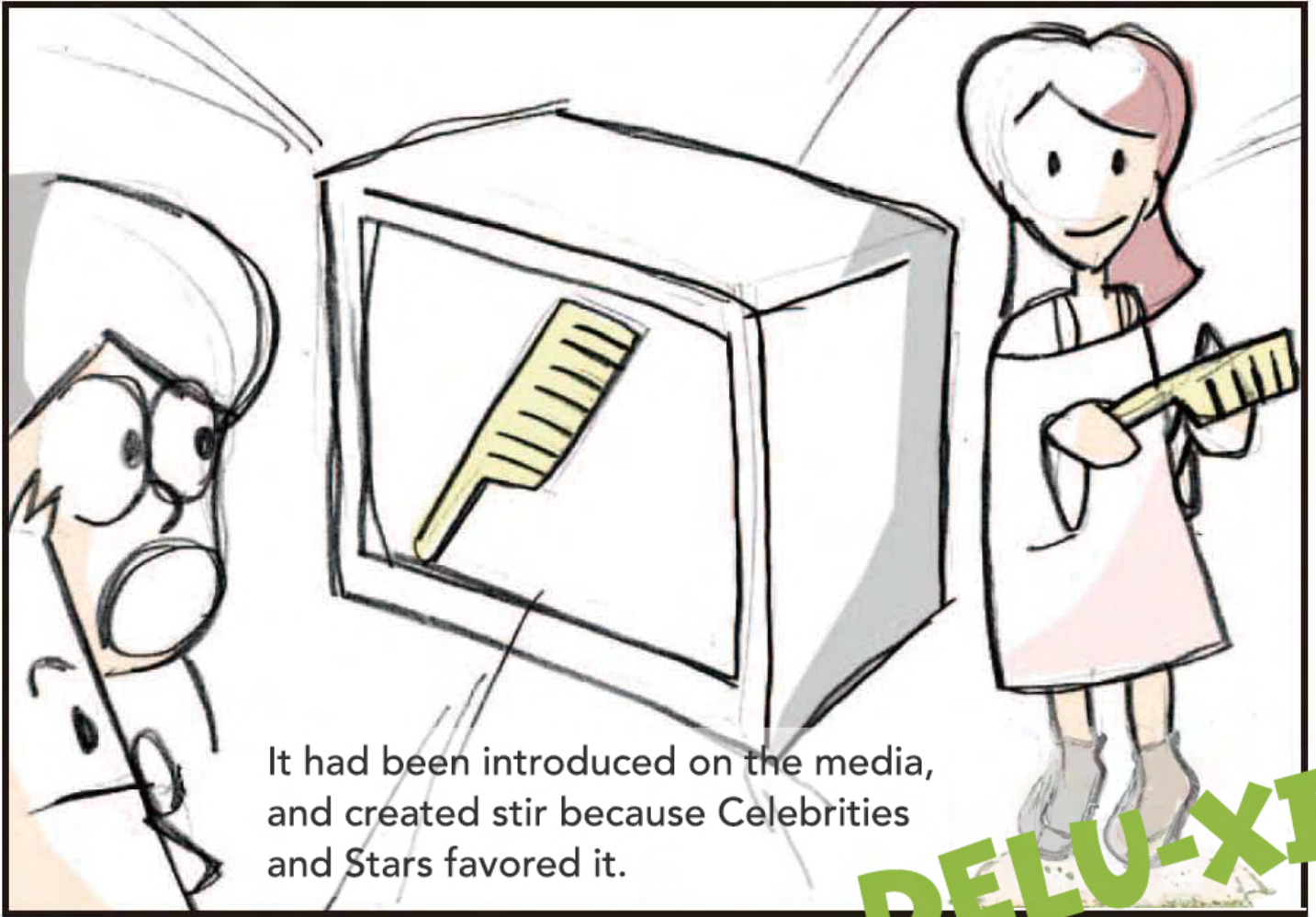

It had been introduced on the media,
and created stir because Celebrities
and Stars favored it.

DELU-XI

TAKETORI Firm made the
growth ever since its
foundation.

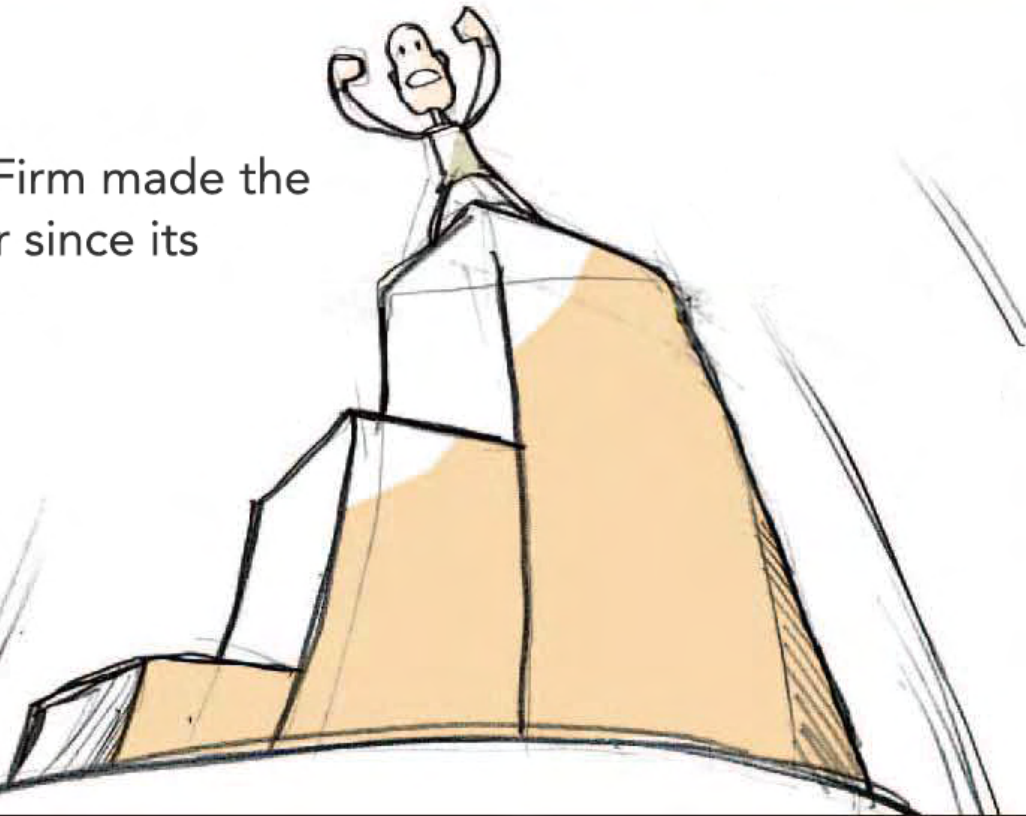

Another afternoon...

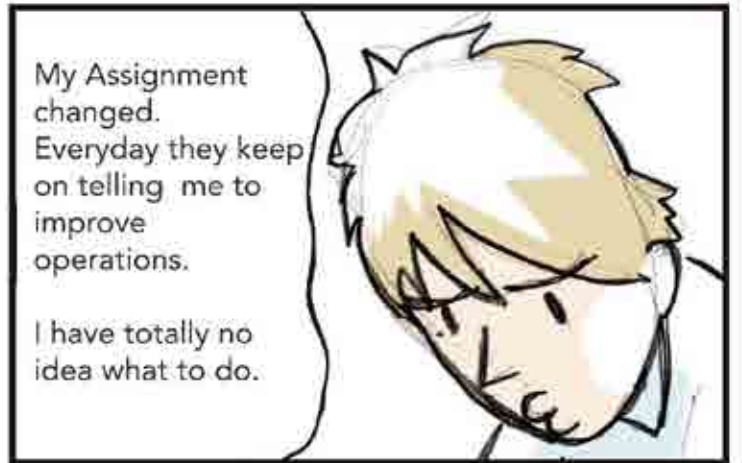
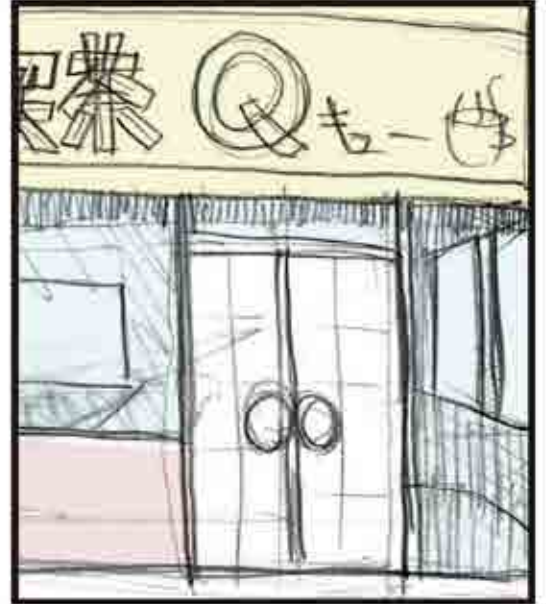
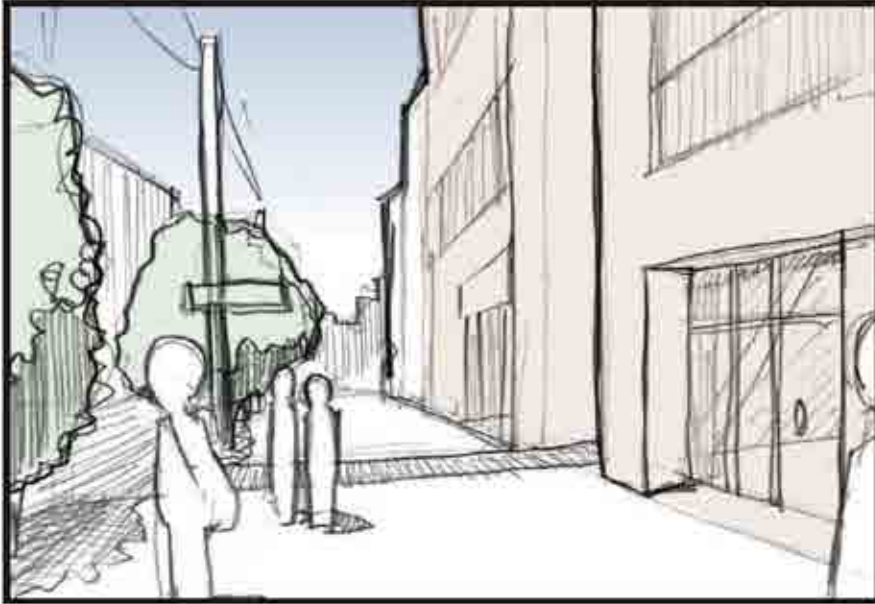

Ha! This boy acts as if he is already a BPM Master.
Now, he found pupil of his own! Well, it's alright...
Now, It's good time for get myself a new pupil... Ho Ho Ho



Rome wasn't built in a day... and so as BPM...

END